

PLAN

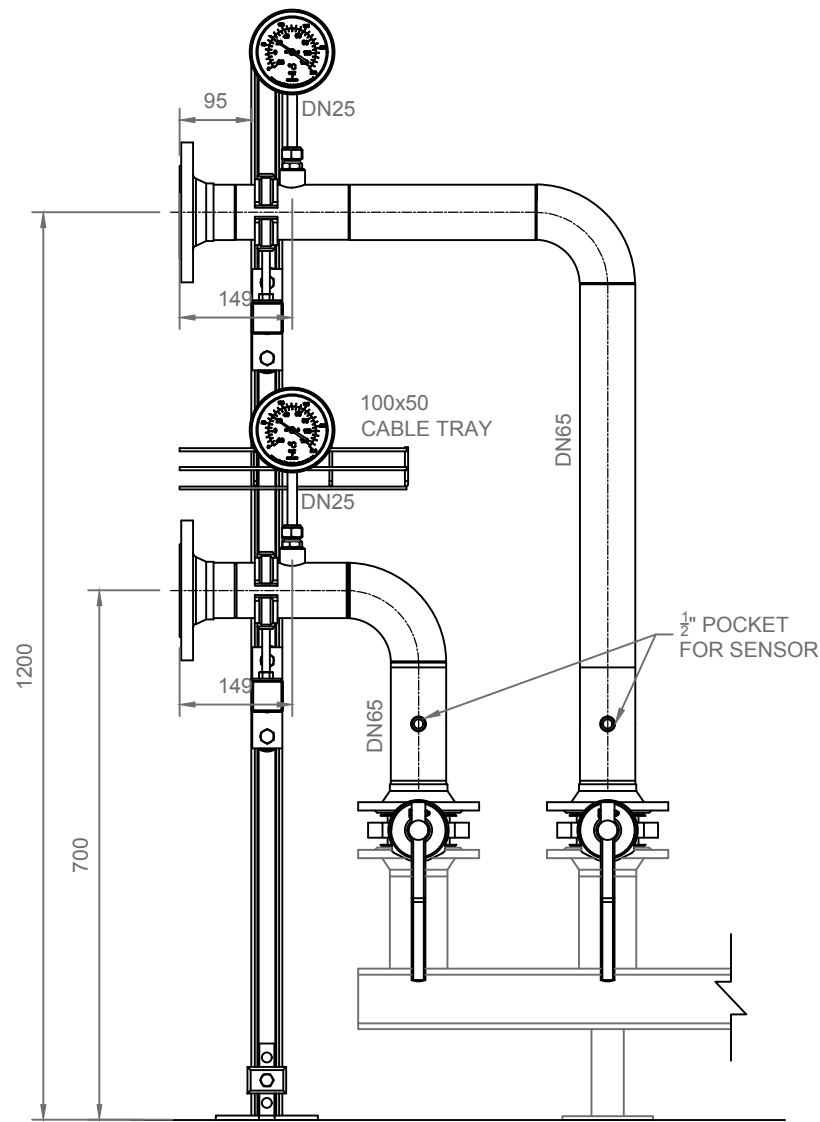

ELEVATION

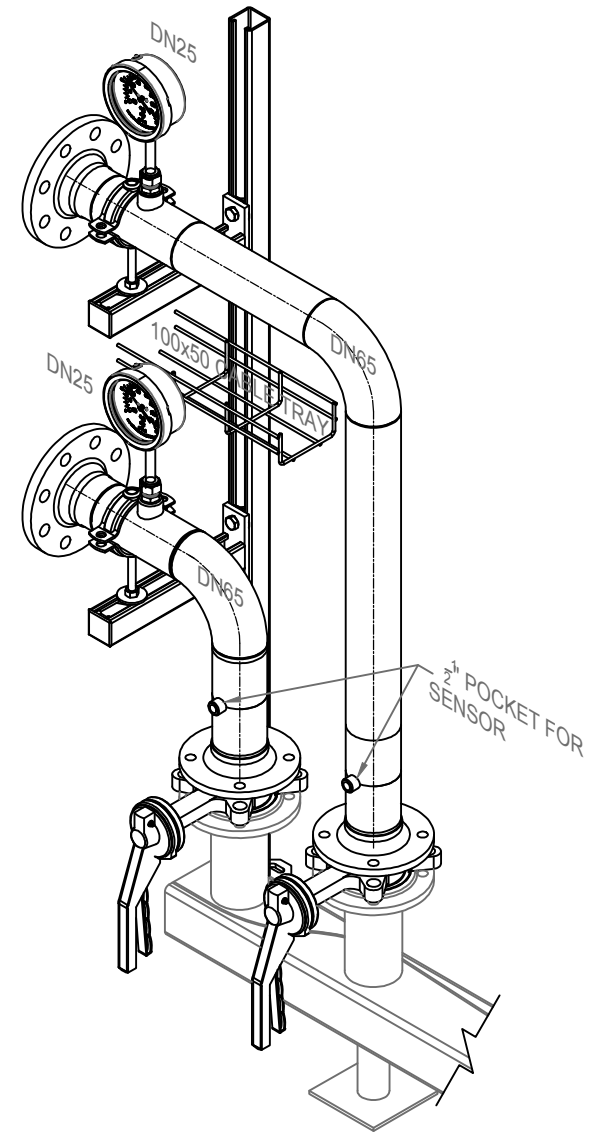

NOTE: ALL DIMENSIONS ARE IN MM UNLESS OTHERWISE STATED.



DRAWN:
ALIHASAN
CHECKED:
DATE:
09-11-2018

MODULE - 5
SKID GENERAL ARRANGEMENT

| REV | DATE | DESCRIPTION |
|-----|------|-------------|
| | | |
| | | |
| | | |

| | |
|-------------|---------|
| DRAWING NO. | DWG-001 |
| SCALE | 1:10 |